

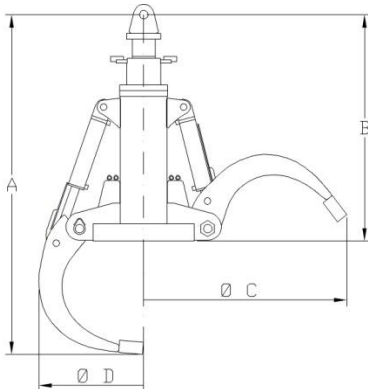

BROCHURE PHEM RANGE

Very strong polyp grabs with an integrated powerful electromagnet, suitable for material handling machines with or without electric generator.

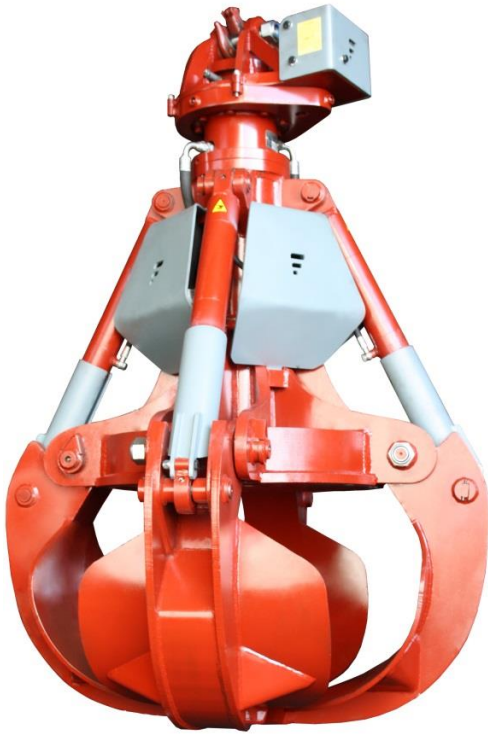

MODEL	ELECTROMAGNET POWER	CAPACITY LT.	MAX .BAR	TINES Nº	WEIGHT KG.	 Ton.	A	B	C	D
							mm.			
PHEM 24V M (GHC 18T)	24 V. 1,5 KW.	400	300	4	1250	15 – 24	1300	1950	1200	2350
PHEM 2220V L (GHC 20T)	220 V. 4KW.	600	300	4	2000	25 – 35	1400	2100	1450	2800